

Installation Manual

L.TRA.DA14.C.M (RWD Double Tire) Ford Transit 350-470 (2014 Onwards)

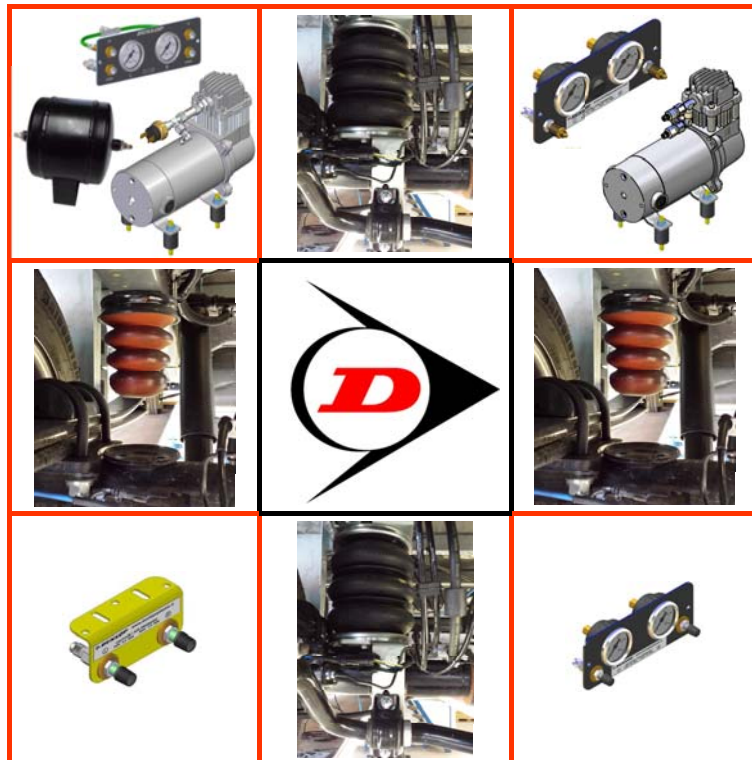



Ford Transit 350 - 470

L.TRA.DA14.C.M

CONTENTS

1. FOREWORD	3
2. INTRODUCTION.....	4
3. VERY IMPORTANT NOTES.....	5
4. OVERVIEW.....	6
5. INSTRUCTIONS FOR INSTALLATION	7
5.1. Attachment of the Adaptor Bracket for the Brake Pipes.....	7
5.2. Replacement of the Axle Breather.....	8
5.3. Removal of Bump Stop and attachment of Upper Bracket.....	8
5.4. Attachment of the Lower Bracket.....	8
5.5. Installation of the Air Springs.....	9
5.6. Repositioning of the Connectors	9
5.7. Fitting of Inflator Console	10
5.8. Tube Connection and Disconnection, Cutting and Routing	12
5.9. Spring Inflation.....	13
5.10. Spring Alignment.....	14
5.11. Maintenance	14
5.12. Check List	15
6. INSTALLATION PHOTOS	17
7. EPILOGUE	22

DSC Nederland B.V.
Het Wegdam 22
7496 CA Hengevelde
Nederland
Tel. : +31 (0)547 333065
Fax. : +31 (0)547 333068
e-mail: info@dunlopsystems.nl
Website: www.dunlopsystems.nl

© 2017, DSC Nederland B.V.



Ford Transit 350 - 470

L.TRA.DA14.C.M

1. FOREWORD

This manual provides instructions for the installation of an auxiliary air suspension kit, developed specifically for the Ford Transit Rear Wheel Drive Double Tire (2014—onwards). To ensure correct installation of the kit, it is strongly recommend that these instructions are read thoroughly before commencing any installation work. Installation should only be carried out by a suitably qualified mechanic or specialist installation facility. DSC Nederland will not accept any responsibility for faults or defects arising from incorrect installation, which automatically renders the guarantee invalid.

IMPORTANT : Manufacturer's Declaration Form

A manufacturer's declaration form is provided with your kit. Following installation of the kit please ensure that this form is completed, signed by a qualified fitter and a copy is returned to DSC Nederland by post, fax or e-mail. Our e-mail address is: info@dunlopsystems.nl



Ford Transit 350 - 470

L.TRA.DA14.C.M

2. INTRODUCTION

Thank you for choosing an auxiliary air suspension kit from the range offered by *DSC Nederland*. Auxiliary air suspension is fitted in tandem with the standard steel springs of the vehicle suspension, and provides enhancements in terms of both the stability of the vehicle and the comfort of the passengers...

Vehicle Levelling

Simply by varying the air pressure in the springs, the vehicle can be levelled both front-to-rear and side-to-side. Keeping the vehicle level optimises stability, ensures correct headlamp beam distribution and reduces tyre wear arising from uneven distribution of weight.

Straight Line Stability

Straight line stability is greatly increased at higher speeds, and when subjected to buffeting from cross-winds or large overtaking vehicles.

Reduced Body Roll

Body roll when cornering or negotiating roundabouts is significantly reduced.

Fatigue Reduction and Wear Compensation

Suspension fatigue is reduced, so helping to prevent leaf springs from sagging under repeated or constant loading. Any sagging already present can be compensated-for. This is a particular benefit for motorhomes, which are always fully laden.

Ride Comfort

Air springs help to absorb shock loads from uneven road surfaces, therefore general ride quality is much improved.

3. VERY IMPORTANT NOTES



Gross Vehicle Weight (GVW)

Air assist kits are not in themselves designed to increase the gross vehicle weight (GVW) rating of a vehicle. They do not legally allow for carriage of a load greater than the carrying capacity stated on the data plate of the vehicle.

Do not exceed the maximum load specified by the vehicle manufacturer...

- ◆ to avoid compromising passenger safety
- ◆ to prevent possible damage to the vehicle
- ◆ for legal reasons

Vehicle Uprating

Despite the above words of caution, it is possible to upgrade the weight rating of your vehicle. This must be carried-out by a specialist supplier that will...

- ◆ carry out any necessary modifications in addition to fitting the air assist kit
- ◆ complete documentation as necessary to inform the Vehicle and Operator Services Agency (VOSA) – a mandatory requirement
- ◆ supply and fit a new weight plate to replace the original plate supplied with the vehicle

This process applies to United Kingdom registered vehicles. The process in other countries may be different.

This process applies to United Kingdom registered vehicles. The process in other countries may be different.

Safety Guidance Note

The following very useful guidance note is available for free download from the *Health and Safety Executive (HSE)*...

PM85, July 2007 *Safe recovery (and repair) of buses and coaches fitted with air suspension*

The uniform resource locator (URL) for this document is...

<http://www.hse.gov.uk/PUBNS/pm85.pdf>

Ford Transit 350 - 470
L.TRA.DA14.C.M

4. OVERVIEW

Number	Part Number	Description	Quantity
1	21.17.00.1.01.01	Top bracket left and right	2
2	21.06.00.1.01.02	Top bracket part 2 left and right	2
3	21.17.00.1.04	Lower bracket left side	1
4	21.17.00.1.05	Lower bracket right side	1
5	21.17.00.1.31.01	Break line adaptor bracket	1
6	OP.LB.170-3.CPL	Air bellow 170/3	2
7	DIN 985 M10	Self locking nut	4
8	DIN 125A M10	Washer	8
9	DIN 933 M10 x 35	Hexagon bolt	2
10	DIN 933 M8 x 20	Hexagon bolt	1
11	DIN 125A M8	Washer	10
12	DIN 985 M8	Self locking nut	5
13	DIN 933 M8 x 25	Hexagon bolt	4
14	DIN 933 M8 x 16	Hexagon bolt	6
15	M8	Disc spring washer	6
16	DIN 7991 M10 x 25	Countersunk bolt	2
17	OPN.OK.6x1/8	Knee fitting for 6mm hose	1
18	OPS.6x4.ZWAR	6mm black hose, L= 95cm	1

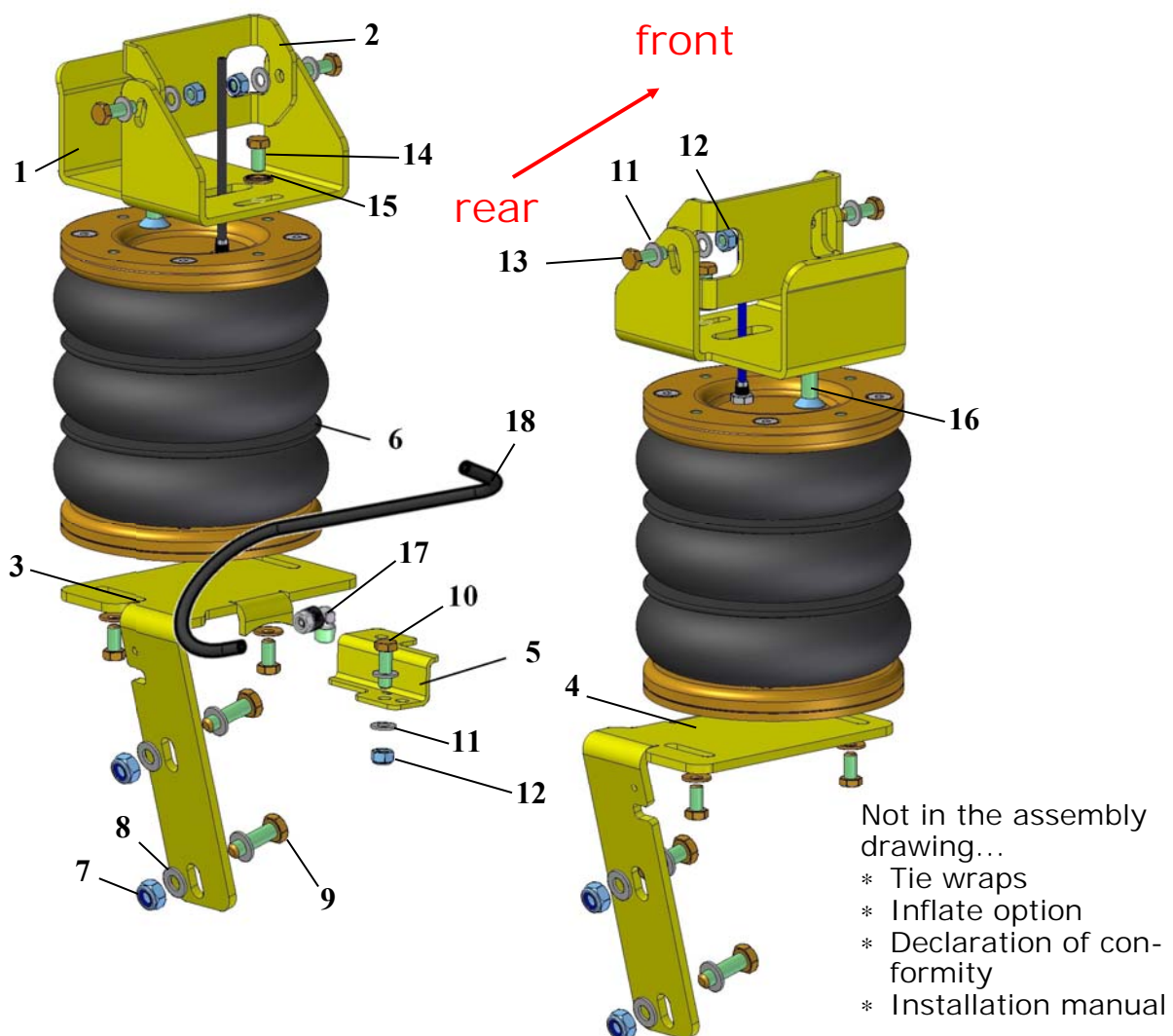

Ford Transit 350 - 470
L.TRA.DA14.C.M

5. INSTRUCTIONS FOR INSTALLATION



Preparation and Precaution

Before beginning installation, ensure that you have sufficient clearance between the axle and the chassis. Use a jack if necessary. Install at one side of the vehicle at a time.



Pay attention to your safety at all times during installation - always use axle stands to support the vehicle!



Recommended Tightening Torque

During fitting of the air suspension system, it is recommended that nuts and bolts are tightened in accordance with the following table...

METRIC TORQUE CHART IN N.m		
SIZE	CLASS 8.8	CLASS 10.9
M6 x 1	9.9	14.0
M8 x 1.25	24.0	34.0
M10 x 1.5	48.0	67.0
M12 x 1.75	83.0	117.0
M16 x 2	200.0	285.0

- When both the bolt and nut are made from steel use either class 8.8 or 10.9
- For all other materials, tightening torque is left to the discretion of a person skilled in the art

The following instructions make reference to the diagrams on pages 17 to 21 inclusive.

5.1 Attachment of the Adaptor Bracket for the Brake Pipes

- i. Unscrew the bracket that connects the brake pipes to the axle, photo 1 and 2
- ii. Attach the adaptor bracket supplied with the kit to the axle, by reusing a M8 bolt, photo 3
- iii. Attach the brake pipe bracket to the adaptor bracket, photo 4 and 5



Ford Transit 350 - 470

L.TRA.DA14.C.M

5.2 Replacement of the Axle Breather

- i. Remove the original hose attached to the nipple. Photo 6
- ii. Unscrew the original straight nipple.
- iii. Insert the elbow nipple and ensure that the screw winding is equal to the surface of the axle, use some fluid seal or Teflon tape.
- iv. Assure that the elbow nipple is pointing to the rear side of the vehicle, photo 7.
- v. Connect the 6 mm hose to the nipple and guide the hose along the brake hose in to a chassis beam, photo 8 and 9.
- vi. Secure the hose of the nipple to the break hose with some tie wraps.

5.3 Removal of Bump Stop and Attachment of Upper Bracket

- i. At the left side disconnect the cable loom and reposition the cable loom on top of the brake lines, photo 10 and 11.
- ii. Unscrew and remove the bump stop, photo 12 - 16.
- iii. Attach the upper bracket to the chassis using a single M10 x 25mm countersunk bolt, making use of the hole left vacant by removal of the bump stop, photo 17.
- iv. Push the upper part of the bracket fully downwards by using a plastic hammer, then tighten the two bolts that join the two parts of the bracket, photo 18 - 20

5.4 Attachment of the Lower Bracket

- i. Unlock both connectors from their bracket, photo 21, 22.
- ii. Disconnect the anti roll bar, photo 23.
- iii. And remove the M10 clips, photo 24.
- iv. Inset the M10 bolt from front to rear, photo 25.
- v. Install the lower bracket.
- vi. Assure that the brackets are resting on the welded disc from the rear axle, photo 26.
- vii. Tighten the anti roll bar with the M10 self securing nuts, photo 27



Ford Transit 350 - 470

L.TRA.DA14.C.M

5.5 Installation of the Air Springs

- i. Bring the air tube through the biggest hole of the upper bracket, Black is Left and Blue is Right, photo 28.
- ii. Connect the air tube to the air bellow, photo 29 (Section 5.8)
- iii. Bring the air spring in its position, guide the air tube.
- iv. Attach the air spring to the lower bracket using two M8 x 16mm bolts and two M8 Spring disc washers, photo 30-32. Do not fully tighten the bolts at this stage because the bellow may require alignment once inflated (Figure 34, Section 5.10).
- v. Attach the upper bracket to the top plate of the air spring using one M8 x 16mm bolts and spring disc washers, photo 33. Do not fully tighten the bolts at this stage because the bellow may require alignment once inflated (Figure 34, Section 5.10).

5.6. Repositioning of the Connectors

- i. Align the air springs according Section 5.10.
- ii. Position the first connector in the 5 mm hole of the lower bracket, photo 35.
- iii. Position the second connector in its original place, photo 36, 37.
- iv. The second connector will also secure the first connector.
- v. Guide and secure the air tubes and electric wiring that were repositioned.
- vi. Tie wraps securing air tubes may not be tightened too strong. The air tube must be able to shift slightly. Otherwise an air leakage can occur soon. (Section 5.8).
- vii. When finished wax all the steel parts (Section 5.11).

Ford Transit 350 - 470
L.TRA.DA14.C.M

5.7 Fitting of Inflator Console

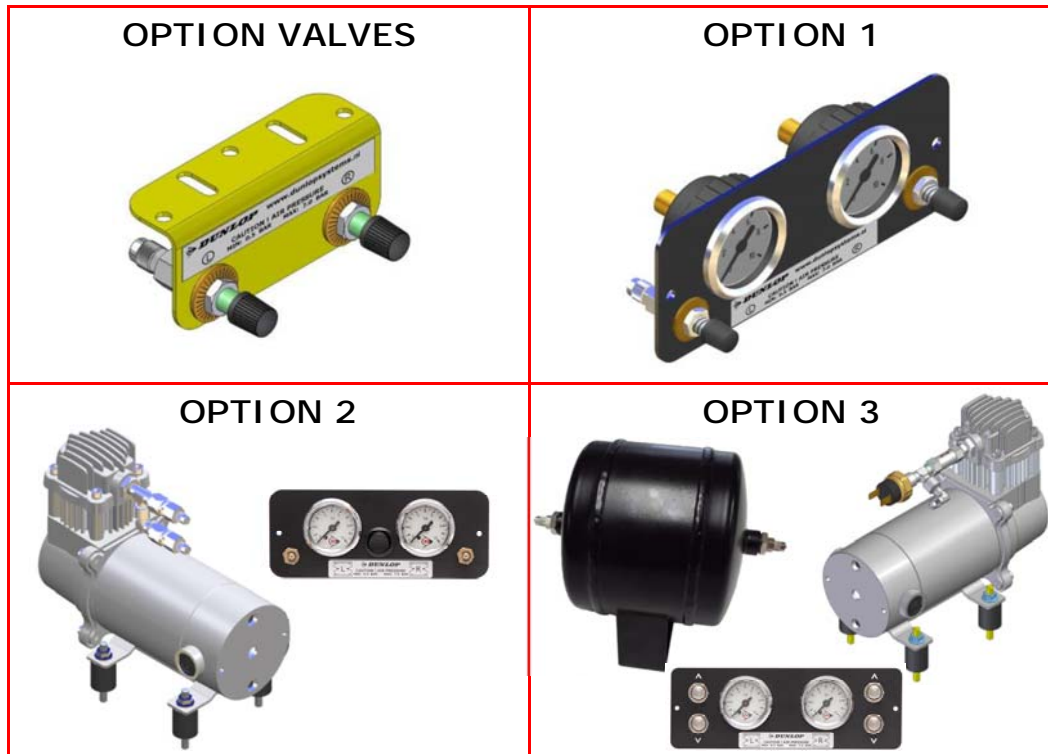

Your kit is supplied with one of the inflator options shown above...

- **OPTION VALVES** : Two valves and a small bracket
- **OPTION 1** : Two valves in a console with two independent 10-bar pressure gauges
- **OPTION 2** : Two valves in a console with two independent 10-bar pressure gauges and a rocker on/off switch to operate the electric motor driven air compressor
- **OPTION 3** : Four valves (two for raising the vehicle ('UP') and two for lowering the vehicle ('DOWN')) in a console with two independent 10-bar pressure gauges. A pressure switch operates the electric motor driven air compressor to keep the air reservoir of 2.2-litre at pressure.



A special dashboard panel is available for **OPTION 1** and **OPTION 2**

Ford Transit 350 - 470

L.TRA.DA14.C.M

Mount the console in a position of your choice whereby it is firmly fixed, has some protection from the environment (particularly important for the console with gauges) and is easily accessible. Suggested possible locations include...

'Standard' Console...

- on the rear bumper
- at the rear beside the license plate
- on the chassis next to a rear wheel
- in a service shutter (motorhomes)
- beside the fuel cap

'Option 1', 'Option 2' or 'Option 3' Console...

- in the vehicle cabin, within reach and sight of the driver
- Beside, under the driver seat
- in the wall of a cupboard (motorhomes)
- in a service shutter (motorhomes)

'Comfort' Packages

The 'Option 2' and 'Option 3' panels, as shown above, are each part of a *Comfort Package* that is supplied with a compressor (and also an air reservoir in the case of the 'Option 3' panel) for ease of spring inflation and ride height setting. For further information please ask your dealer.

The photograph below shows all of the parts of Comfort Package 'Option 2'...



Comfort Package 'Option 2'

5.8 Tube Connection and Disconnection, Cutting and Routing

Connection and Disconnection

Tubes are connected as shown by the diagrams below...

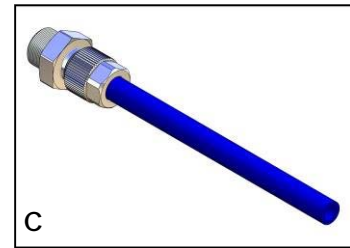
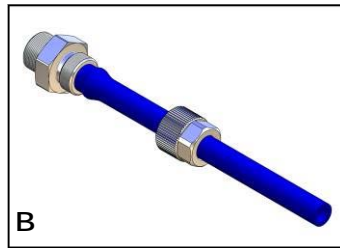
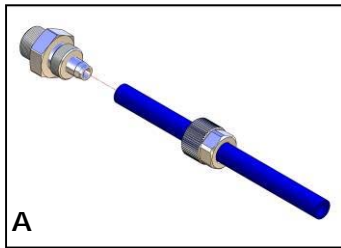

- Slide a nut over the end of the tube
- Push the tube onto the connector as far as possible
- Feed the nut up to the connector, fully tighten by hand and finally tighten one additional turn using spanners

Cutting

To achieve good sealing and air-tight fitting of tube ends to their connecting parts, it is very important to cut tubing cleanly and squarely. A dedicated guillotine action tubing cutter is recommended, or a craft knife if such a tool is not available. Do not use electrician's side cutters.



A dedicated tubing cutter -
Recommended



Electrician's Side Cutters
NOT Recommended

Ford Transit 350 - 470

L.TRA.DA14.C.M

Routing

Study the underside of the vehicle and decide how to route each branch of the air circuit...

- To minimise the risk of chafing, avoid running tubing over metal edges as much as possible
- Avoid close proximity to heat sources such as the exhaust assembly
- Choose a route that provides as much protection as possible from dirt, debris and any solid objects that may impact the underside of the vehicle

It is recommended that tubes are guided alongside brake lines as much as possible.



Use cable ties ('tie wraps') to secure tubing to the chassis, taking care not to over-tighten them.

5.9 Spring Inflation

Once installation of the air assist kit is complete, inflate the springs to achieve the desired ride height via the inflator console taking careful note of the following...



Maximum and Minimum Pressure

Maximum Pressure 7.0bar

Minimum Pressure 0.5bar

Do not exceed 7.0bar (101psi), which is the recommended maximum charge pressure for the air springs.

The springs may be deflated if the vehicle is to be stored for a lengthy period without use, but a pressure of at least 0.5bar (7.25psi) should be maintained at all times in order to avoid possible compression damage to the springs.

With the vehicle standing at the desired ride height, it is recommended that the height of the bellow itself should be between 18cm and 22cm.

Ford Transit 350 - 470 L.TRA.DA14.C.M

5.10 Spring Alignment

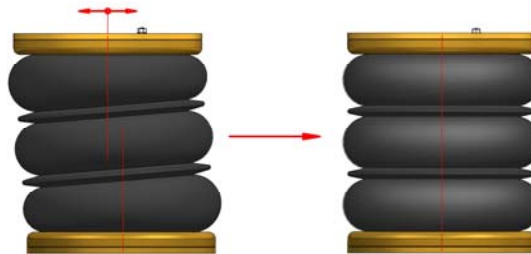

Spring out of alignment
mounting plate axes
offset

Spring in alignment
mounting plates parallel
and coaxial

- i. With the vehicle standing at the desired ride height, ensure that the springs are correctly aligned as illustrated above and then tighten the bolts to secure the bellow to both the upper and the lower mounting brackets.
- ii. Always check if the air bellow won't touch any obstacle

5.11 Maintenance

Following installation, it is recommended that all metal parts are coated with a protective substance such as body wax.

The system does not require very much maintenance other than...

- ◆ to maintain air pressure in the springs. Much like a tyre, the system may lose a little air over time.
- ◆ to keep the air bellows clean. It is suggested that, when washing the vehicle, the bellows are inspected and cleaned as necessary (preferable by spraying). Look in particular for stones or grit trapped between convolutes, as this may damage the bellow.
- ◆ Check before and after the winter period the wax coating. Re-wax when necessarily



Ford Transit 350 - 470
L.TRA.DA14.C.M

5.12 Check List

Before driving the vehicle following completion of installation of the auxiliary air suspension system, please check...

- ...all bolts tightened to the recommended torque (Page 7)?
- ...air springs set in alignment (Section 5.10)?
- ...enough free space around the air springs to avoid wearing?
- ...all metal parts wax coated (Section 5.11)?
- ...manufacturer's declaration form completed and a copy returned?



A wait of 24 hours is recommended in order to ensure that the vehicle has maintained its stance and that there are no air leaks present.

Ford Transit 350 - 470
L.TRA.DA14.C.M

6. INSTALLATION PHOTOS

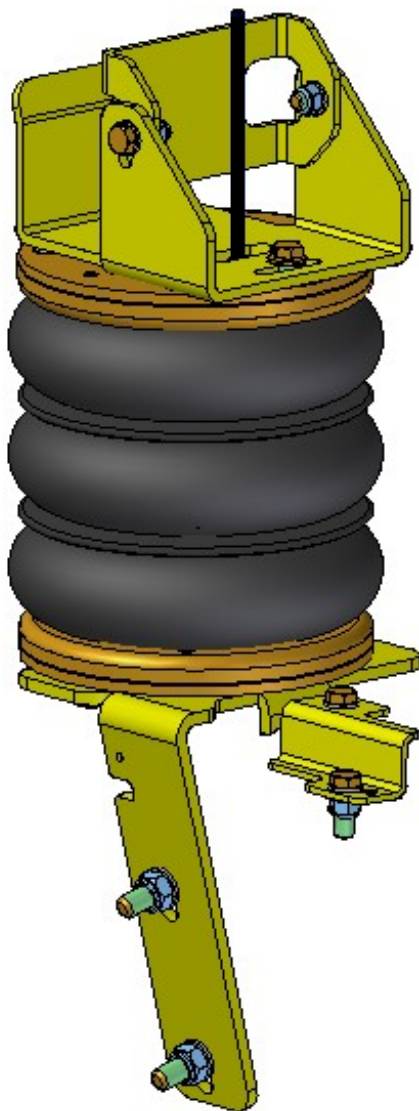

Ford Transit 350 - 470
L.TRA.DA14.C.M

1



2



3



4



5



6

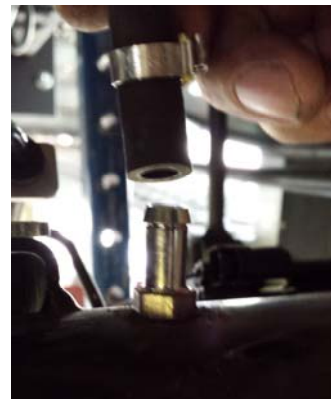

7



8



Ford Transit 350 - 470
L.TRA.DA14.C.M

9

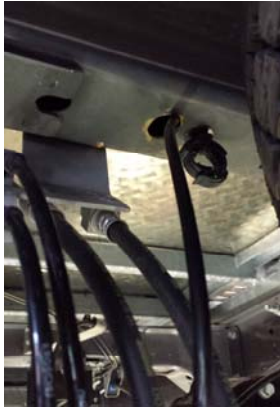

10



11



12



13



14



15



16

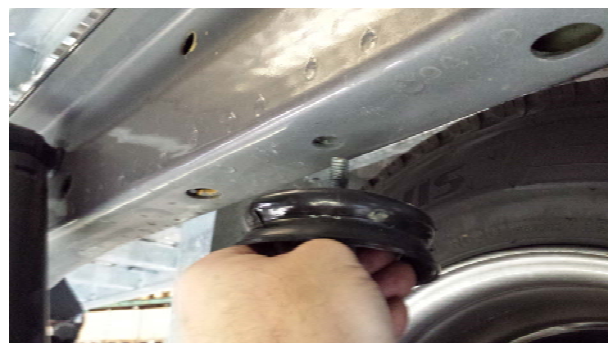

Ford Transit 350 - 470
L.TRA.DA14.C.M

17



18



19



20



21

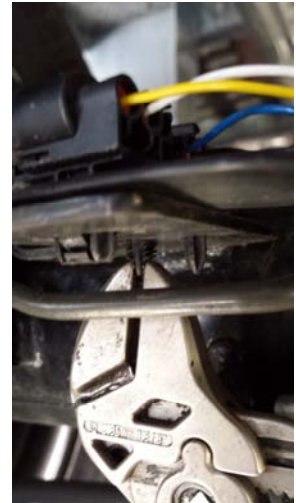

22



23



24



Ford Transit 350 - 470
L.TRA.DA14.C.M

34

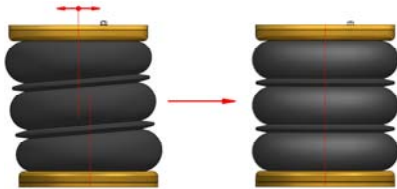

Spring out of alignment mounting plate axes offset

Spring in alignment mounting plates parallel and coaxial



CAUTION!

Before fully tightening the bolts that secure the air spring to the upper and lower brackets, set the vehicle at ride height (spring height ideally between 18cm and 22cm) and ensure that the springs are correctly aligned.

35



36



37



38



39





Ford Transit 350 - 470

L.TRA.DA14.C.M

6. EPILOGUE

DSC Nederland hopes that you enjoy the benefits that your air suspension system will provide for you. To ensure optimal performance, we advise that you have your system checked frequently by qualified personnel. As recommended in the fitting instructions, it is important to coat all the steel parts with a protective substance such as body wax.

IMPORTANT : Manufacturer's Declaration Form

A manufacturer's declaration form is provided with your kit. Following installation of the kit please ensure that this form is completed, signed by a qualified fitter and a copy is returned to DSC Nederland by post, fax or e-mail. Our e-mail address is: info@dunlopsystems.nl

As a condition of your warranty, modifications to the system may only be carried out by personnel of DSC Nederland.

Enquiries

For general enquiries please contact one of our dealers. You can find them on our website.

www.dunlopsystems.nl

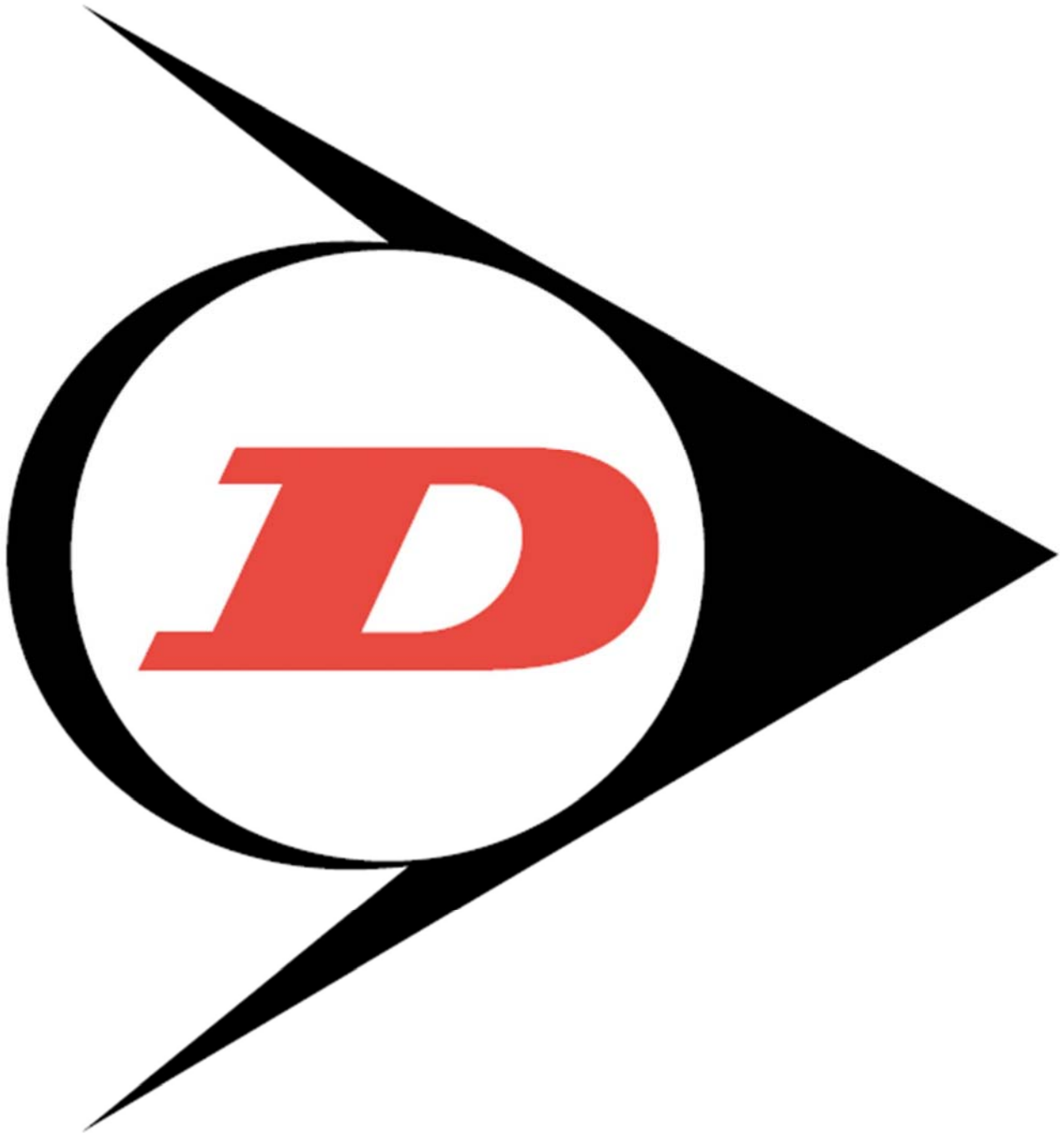

DSC Nederland B.V.
Het Wegdam 22
7496 CA Hengevelde
Nederland
Tel. : +31 (0)547 333065
Fax. : +31 (0)547 333068
e-mail: info@dunlopsystems.nl

www.dunlopsystems.nl