

# Installation Manual

## L.MAS.10.C.M

Nissan NV400, 2010 Onwards  
Opel, Vauxhall Movano 2, 2010 Onwards  
Renault Master X62 2010 Onwards

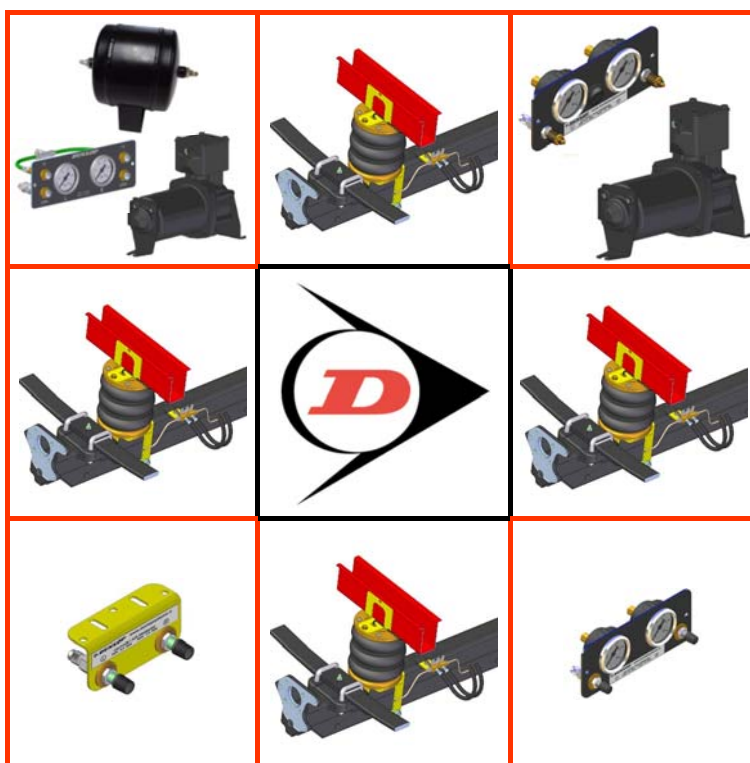



Nissan NV400

Opel Movano

Renault Master

## L.MAS.10.C.M

### CONTENTS

1. FOREWORD .....	3
2. INTRODUCTION .....	4
3. VERY IMPORTANT NOTES.....	5
4. OVERVIEW .....	6
5. INSTRUCTIONS FOR INSTALLATION .....	7
5.1. Recommended Tightening Torque.....	7
5.2. Installation of the air suspension at the right side.....	7
5.3. Installation of the air suspension at the left side.....	8
5.4. Fitting of Inflator Console.....	9
5.5. Tube Connection and Disconnection, Cutting and Routing .....	10
5.6. Spring Inflation.....	11
5.7. Spring Alignment .....	12
5.8. Maintenance.....	12
5.9. Installation Drawings.....	13
6. EPILOGUE .....	16

DSC Nederland B.V.  
Het Wegdam 22  
7496 CA Hengevelde  
Nederland  
Tel. : +31 (0)547 333065  
Fax. : +31 (0)547 333068  
e-mail: [info@dunlopsystems.nl](mailto:info@dunlopsystems.nl)  
Website: [www.dunlopsystems.nl](http://www.dunlopsystems.nl)

© 2017, DSC Nederland B.V.



Nissan NV400

Opel Movano

Renault Master

## L.MAS.10.C.M

### 1. FOREWORD

This manual provides instructions for the installation of an auxiliary air suspension kit, developed specifically for the Renault Master x62, Opel/Vauxhall Movano 2 and Nissan NV400 (2010 onwards) front wheel drive. To ensure correct installation of the kit, it is strongly recommended that these instructions are read thoroughly before commencing any installation work. Installation should only be carried out by a suitably qualified mechanic or specialist installation facility. DSC Nederland will not accept any responsibility for faults or defects arising from incorrect installation, which automatically renders the guarantee invalid.

#### **IMPORTANT : Manufacturer's Declaration Form**

A manufacturer's declaration form is provided with your kit. Following installation of the kit please ensure that this form is completed, signed by a qualified fitter and a copy is returned to DSC Nederland by post, fax or e-mail. Our e-mail address is: [info@dunlopsystems.nl](mailto:info@dunlopsystems.nl)



Nissan NV400

Opel Movano

Renault Master

## L.MAS.10.C.M

### 2. INTRODUCTION

Thank you for choosing an auxiliary air suspension kit from the range offered by *DSC Nederland*. Auxiliary air suspension is fitted in tandem with the standard steel springs of the vehicle suspension, and provides enhancements in terms of both the stability of the vehicle and the comfort of the passengers...

#### **Vehicle Levelling**

Simply by varying the air pressure in the springs, the vehicle can be levelled both front-to-rear and side-to-side. Keeping the vehicle level optimises stability, ensures correct headlamp beam distribution and reduces tyre wear arising from uneven distribution of weight.

#### **Straight Line Stability**

Straight line stability is greatly increased at higher speeds, and when subjected to buffeting from cross-winds or large overtaking vehicles.

#### **Reduced Body Roll**

Body roll when cornering or negotiating roundabouts is significantly reduced.

#### **Fatigue Reduction and Wear Compensation**

Suspension fatigue is reduced, so helping to prevent leaf springs from sagging under repeated or constant loading. Any sagging already present can be compensated-for. This is a particular benefit for motorhomes, which are always fully laden.

#### **Ride Comfort**

Air springs help to absorb shock loads from uneven road surfaces, therefore general ride quality is much improved.



Nissan NV400

Opel Movano

Renault Master

## L.MAS.10.C.M

### 3. VERY IMPORTANT NOTES



#### Gross Vehicle Weight (GVW)

Air assist kits are not in themselves designed to increase the gross vehicle weight (GVW) rating of a vehicle. They do not legally allow for carriage of a load greater than the carrying capacity stated on the data plate of the vehicle.

Do not exceed the maximum load specified by the vehicle manufacturer...

- ◆ to avoid compromising passenger safety
- ◆ to prevent possible damage to the vehicle
- ◆ for legal reasons

#### Vehicle Upgrading

Despite the above words of caution, it is possible to upgrade the weight rating of your vehicle. This must be carried-out by a specialist supplier that will...

- ◆ carry out any necessary modifications in addition to fitting the air assist kit
- ◆ complete documentation as necessary to inform the Vehicle and Operator Services Agency (VOSA) – a mandatory requirement
- ◆ supply and fit a new weight plate to replace the original plate supplied with the vehicle

This process applies to United Kingdom registered vehicles. The process in other countries may be different.

#### Safety Guidance Note

The following very useful guidance note is available for free download from the *Health and Safety Executive (HSE)*...

**PM85, July 2007** *Safe recovery (and repair) of buses and coaches fitted with air suspension*

The uniform resource locator (URL) for this document is...

<http://www.hse.gov.uk/PUBNS/pm85.pdf>

## 4. OVERVIEW

The diagram below is an overview of the complete assembly...

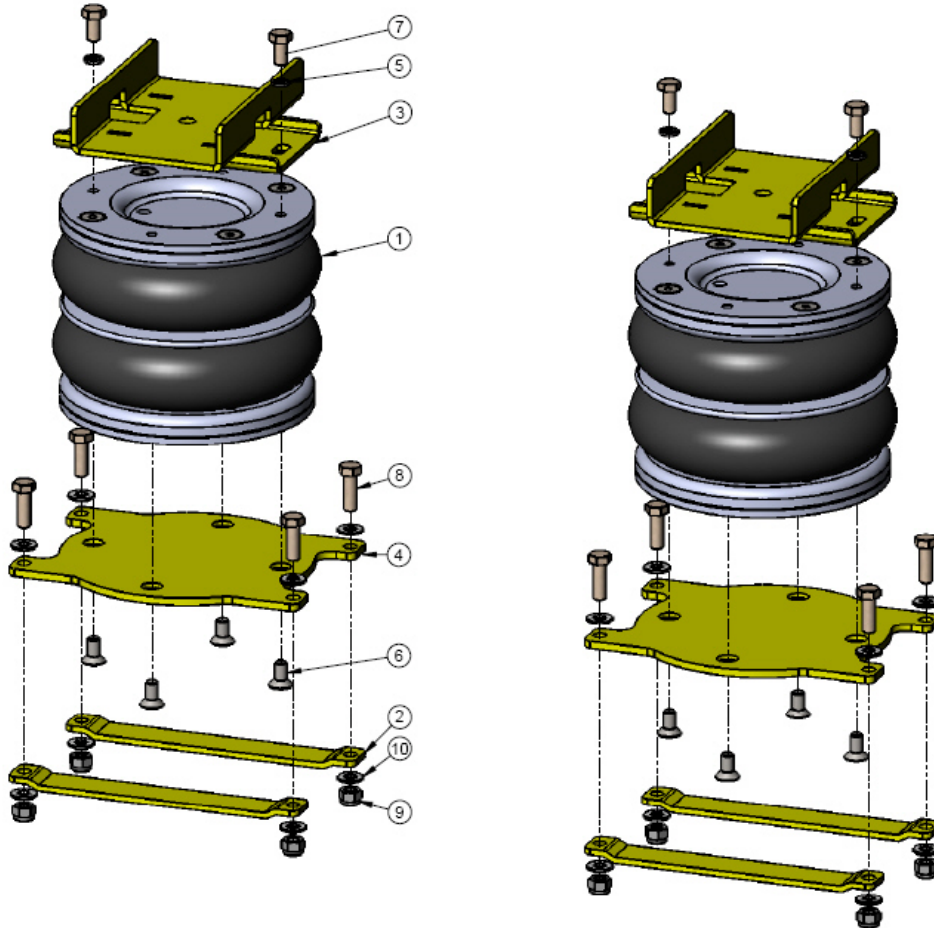

POS	ARTIKELNUMMER	OMSCHRIJVING	AANTAL
1	OP.LB.170-2.CPL	170/2 AIR BELLOW	2
2	65.05.00.1.04.02	STRAP LOWER BRACKET	4
3	65.05.00.1.01	UPPER BRACKET	2
4	65.05.00.1.04.01	LOWER BRACKET	2
5		DISH SPRING WASHER	4
6	DIN 7991-M8x12	M8 x 12 COUNTER SUNK BOLT	8
7	DIN 933-M8x16	HEXAGON BOLT M8 x 16	4
8	DIN 933-M8x25	HEXAGON BOLT M8 x 25	8
9	DIN 985-M8	SELF LOCKING NUT M8	8
10	DIN 125A-M8	WASHER M8	16

## 5. INSTRUCTIONS FOR INSTALLATION



### Preparation and Precaution

Before beginning installation, ensure that you have sufficient clearance between the axle and the chassis (at least 25cm). Use a jack if necessary. Install at one side of the vehicle at a time.



Pay attention to your safety at all times during installation - always use axle stands to support the vehicle!



Start by jacking up the rear side till approximately driving level and measure the distance between the rear axle and the chassis at the location of the bump stop. This should be app. 14 cm. If this is app. 18 cm you will need a 3convolute air bellow.

### 5.1 Recommended Tightening Torque

During fitting of the air suspension system, it is recommended that nuts and bolts are tightened in accordance with the following table...

METRIC TORQUE CHART in N.m			
SIZE	CLASS 8.8	CLASS 10.9	Aluminium and PA6G
M6 x 1	10	14	4
M8 x 1.25	23	34	9
M10 x 1.25*	51	72	20
M10 x 1.5	48	67	18
M12 x 1.75	83	117	31
M16 x 2	200	285	80

- When both the bolt and nut are made from steel use either class 8.8 or 10.9
- For all other materials, tightening torque is left to the discretion of a person skilled in the art



Nissan NV400

Opel Movano

Renault Master

## L.MAS.10.C.M

The following instructions make reference to the diagrams on pages 14 to 15 inclusive.

### 5.2 Installation of the air suspension at right side

1. Remove the bump stop. You can easily push the bump stop out of it's holder. The M10 bolt is to be reused for the mounting of the upper bracket (Photo 1,2 & 3).
2. Install the upper bracket with it's original bolt. (Photo 4 & 5). The hole to guide the air hose trough has to be on the inside.
3. Check if the countersunk bolts of the lower bracket are properly tightened.
4. Guide the blue air hose through the hole on the inside and connect it to the air bellow (Photo 6 & 7). Caution! Don't tighten the special nut of the air line not to tight (See Section .....).
5. Bring the air bellow into position on the rear axle and install both M8 bolt with dish washer finger tight oat the top side. (see Photo 8 & 9).
6. Shift both strap trough the opening of the rebound plate and install the M8 bolts with washers and self locking nuts finger tight till it is still able to shift the air bellow (Photo 10).

### 5.3 Installation of the air suspension at the left side

1. Item 1 till 3 are identical to the right side.
4. Guide the back air hose through .....
5. Item 5 and 6 are identical to the right side.
7. Bring the vehicle till driving height (when the vehicle is almost totally empty you have to bring weight into the vehicle). Driving height is app. 13.5 cm ,of course can this height be modified a little on request of the Vehicle owner.
8. Before tightening all bolts and nuts definitely, the air bellow needs to be aligned. See section



## 5.4 Fitting of Inflator Console

Option Valves



Option 1



Option 2



Option 3



Your kit is supplied with one of the inflator options console shown above...

- 'Option Valves', having two valves and a bracket (above, top-left)
- 'Option 1', 'Option 2' or 'Option 3', having both valves and pressure gauges

Mount the console in a position of your choice whereby it is firmly fixed, has some protection from the environment (particularly important for the console with gauges) and is easily accessible. Suggested possible locations include...

### Console with Valves Only...

- on the rear bumper
- at the rear beside the license plate
- on the chassis next to a rear wheel
- in a service shutter
- beside the fuel cap

### Console with Valves and Gauges...

- in the vehicle cabin, within reach and sight of the driver
- in the wall of a cupboard (motorhomes)
- in a service shutter

### 'Comfort' Packages

The 'Option 2' and 'Option 3' panels, as shown above, are each part of a *Comfort Package* that is supplied with a compressor (and also an air reservoir in the case of the 'Option 3' panel) for ease of spring inflation and ride height setting. For further information please ask your dealer.

## 5.5 Tube Connection and Disconnection, Cutting and Routing

### Connection and Disconnection

Tubes are connected as shown by the diagrams below...

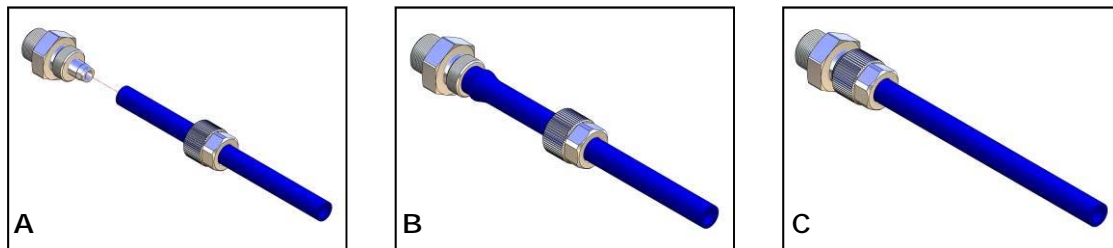

- A. Slide a nut over the end of the tube
- B. Push the tube onto the connector as far as possible
- C. Feed the nut up to the connector, fully tighten by hand and finally tighten one additional turn using spanners

### Cutting

To achieve good sealing and air-tight fitting of tube ends to their connecting parts, it is very important to cut tubing cleanly and squarely. A dedicated guillotine action tubing cutter is recommended, or a craft knife if such a tool is not available. Do not use electrician's side cutters.



A dedicated tubing cutter -  
**Recommended**



Electrician's Side Cutters  
**NOT Recommended**



Nissan NV400

Opel Movano

Renault Master

## L.MAS.10.C.M

### Routing

Study the underside of the vehicle and decide how to route each branch of the air circuit...

- To minimise the risk of chafing, avoid running tubing over metal edges as much as possible
- Avoid close proximity to heat sources such as the exhaust assembly
- Choose a route that provides as much protection as possible from dirt, debris and any solid objects that may impact the underside of the vehicle

It is recommended that tubes are guided alongside brake lines as much as possible.



Use cable ties ('tie wraps') to secure tubing to the chassis, taking care not to over-tighten them.

### 5.6 Spring Inflation

Once installation of the air assist kit is complete, inflate the springs via the inflator console taking careful note of the following...



#### Maximum and Minimum Pressure

**Maximum Pressure 7.0bar**

**Minimum Pressure 0.5bar**

Do not exceed 7.0bar (101psi), which is the recommended maximum charge pressure for the air springs.

The springs may be deflated if the vehicle is to be stored for a lengthy period without use, but a pressure of at least 0.5bar (7.25psi) should be maintained at all times in order to avoid possible compression damage to the springs.

It is wise to hand over the vehicle 24 hours after the installation is done. Just to assure the customer will leave with an airtight system.

## 5.7 Spring Alignment

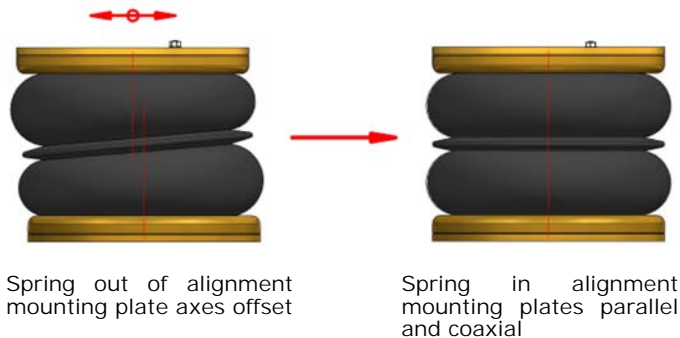

### CAUTION!

Before fully tightening the bolts that secure the air spring to the upper and lower brackets, set the vehicle at ride height (spring height approximately 13.5cm) and ensure that the springs are correctly aligned.

## 5.8 Maintenance

Following installation, it is recommended that all metal parts are coated with a protective substance such as body wax.

The system does not require very much maintenance other than...

- ◆ to maintain air pressure in the springs. Much like a tyre, the system may lose a little air over time.
- ◆ to keep the air bellows clean. It is suggested that, when washing the vehicle, the bellows are inspected and cleaned as necessary (preferable by spraying). Look in particular for stones or grit trapped between convolutes, as this may damage the bellow.
- ◆ Check before and after the winter period the wax coating. Re-wax when necessarily

Nissan NV400

Opel Movano

Renault Master

L.MAS.10.C.M

5.9 Installation Drawings

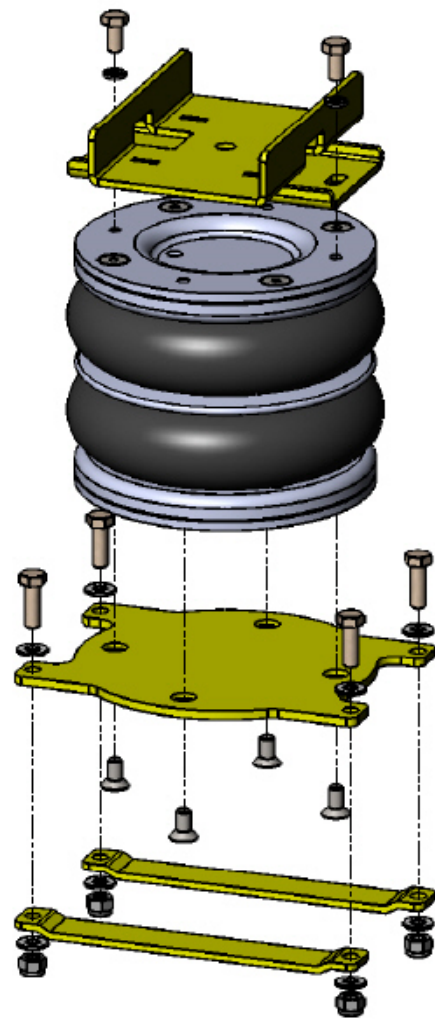
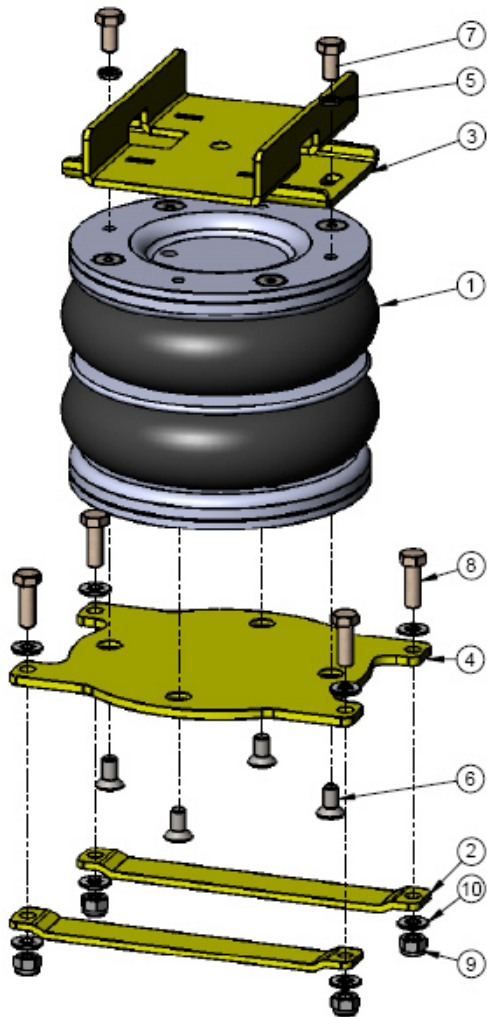

Nissan NV400

Opel Movano  
L.MAS.10.C.M

Renault Master

1



2



3



4



5



6



7



8

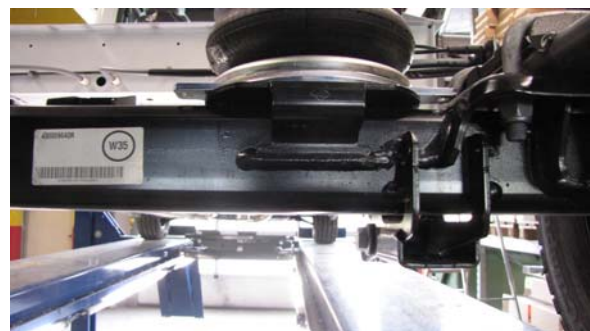

Nissan NV400

Opel Movano  
L.MAS.10.C.M

Renault Master

9



10



11

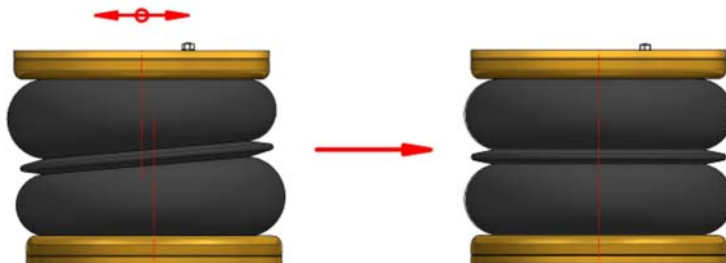

Spring out of alignment—  
mounting plate axes offset

Spring in alignment—mounting  
plates parallel and coaxial



**CAUTION!**

Before fully tightening the bolts that secure the air spring to the upper and lower brackets, set the vehicle at ride height (spring height approximately 13.5cm) and ensure that the springs are correctly aligned.

12

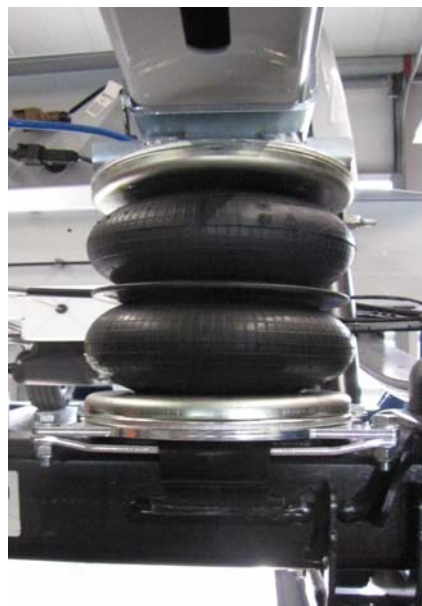



Nissan NV400

Opel Movano

Renault Master

## L.MAS.10.C.M

### 6. EPILOGUE

DSC Nederland hopes that you enjoy the benefits that your *DUNLOP* air suspension system will provide for you. To ensure optimal performance, we advise that you have your system checked frequently by qualified personnel. As recommended in the fitting instructions, it is important to coat all the steel parts with a protective substance such as body wax.

#### **IMPORTANT : Manufacturer's Declaration Form**

**A manufacturer's declaration form is provided with your kit. Following installation of the kit please ensure that this form is completed, signed by a qualified fitter and a copy is returned to DSC Nederland by post, fax or e-mail. Our e-mail address is: [info@dunlopsystems.nl](mailto:info@dunlopsystems.nl)**

As a condition of your warranty, modifications to the system may only be carried out by personnel of DSC Nederland.

#### **Enquiries**

For general enquiries please contact one of our dealers. You can find them on our website.

[www.dunlopsystems.nl](http://www.dunlopsystems.nl)





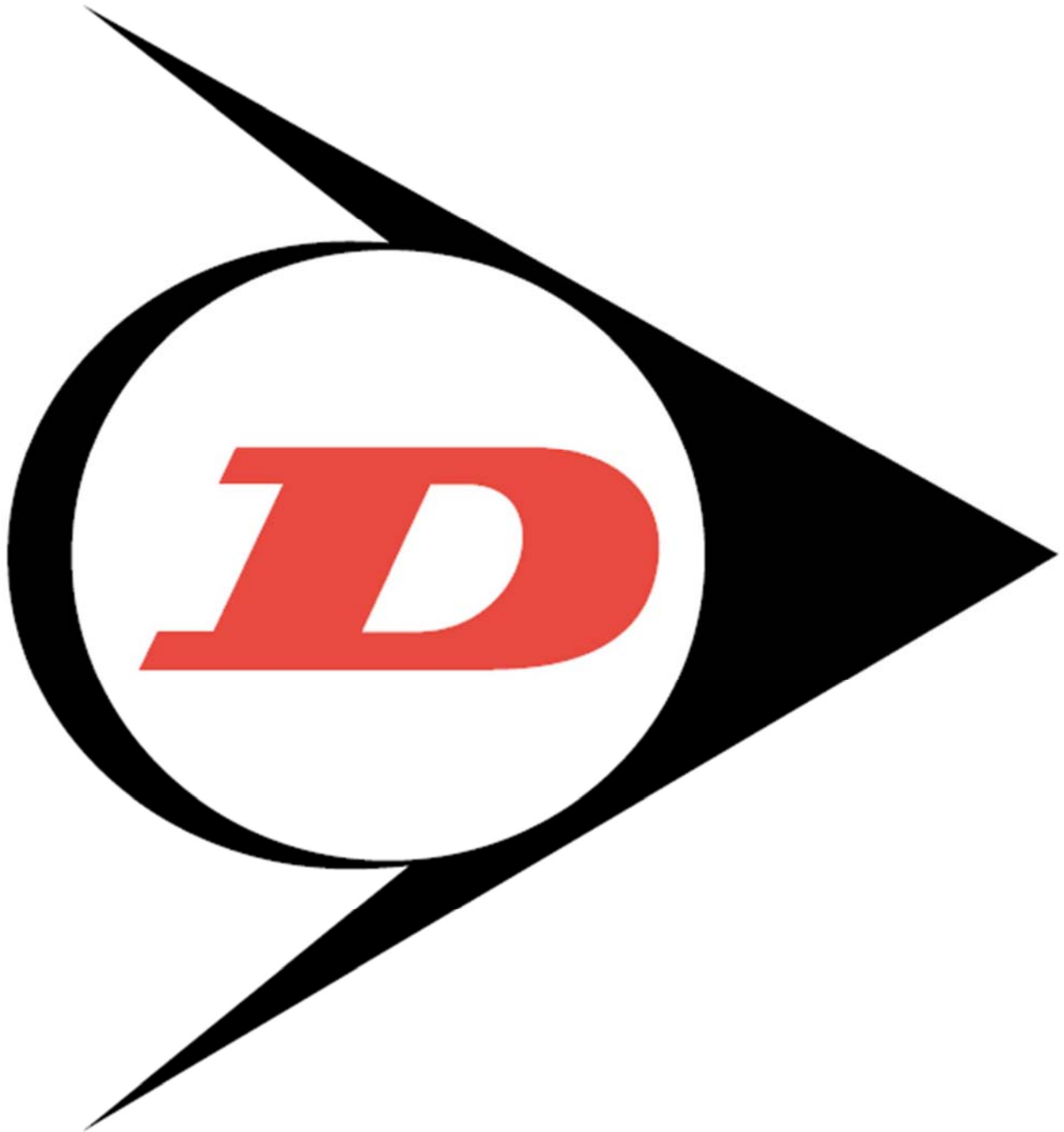

DSC Nederland B.V.  
Het Wegdam 22  
7496 CA Hengevelde  
Nederland  
Tel. : +31 (0)547 333065  
Fax. : +31 (0)547 333068  
e-mail: [info@dunlopsystems.nl](mailto:info@dunlopsystems.nl)

[www.dunlopsystems.nl](http://www.dunlopsystems.nl)